

NOTES:

1. MATERIAL:
SEE THE TABLE
2. FINISH:
2.1 CONTACT:
50u" MIN. NICKEL PLATING OVERALL
100u" MIN. MATT TIN PLATING ON SOLDER TAIL
2: GOLD FLASH PLATING ON CONTACT
2.2 SHELL: 50u" MIN. NICKEL PLATING OVERALL
3. SPEC. PLS. REFER TO SPEC-55911-XXXX-XXX
4. PACKAGE PLS. :
(1)P/N: 55911-0110X-XXX REFER TO:55911-XXXX-001-PCK
(2)P/N: 55911-0117X-XXX REFER TO:55911-XXXX-002-PCK

5. PART NUMBER

55911-011 X X-XXX
 CKTS _____ 001:NONE
 011: 11PIN(W/O Vconn PIN) _____ PLATING
 PACKING _____ 2: GOLD FLASH PLATING ON CONTACT
 0: TAPE & REEL
 7: TAPE & REEL WITH COVER

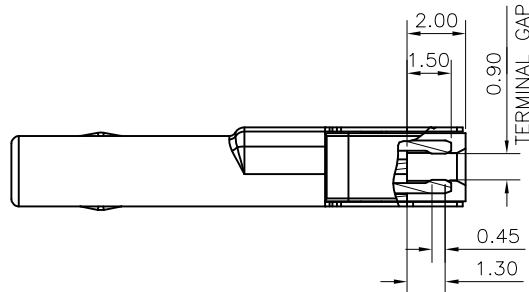
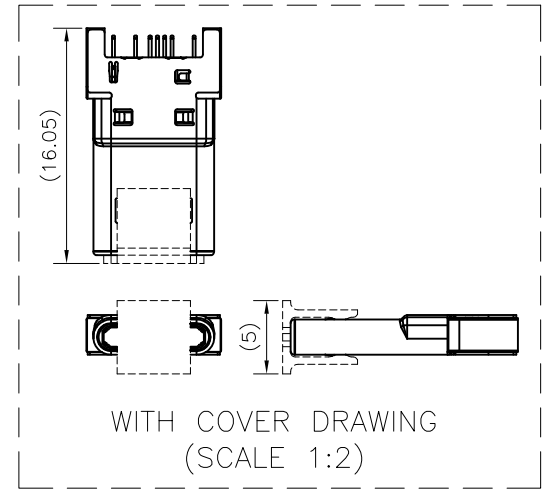
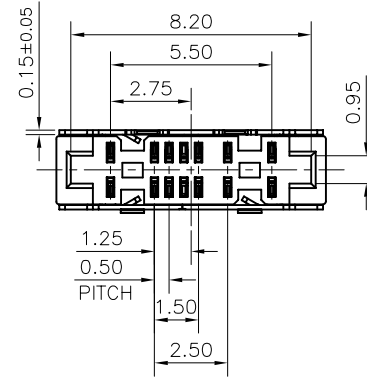
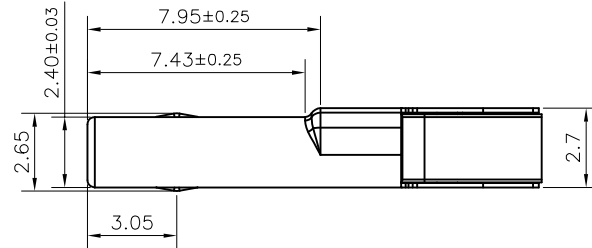
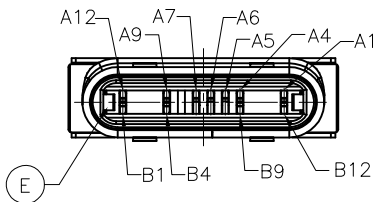

A1	GND	B1	GND
A4	V _{BUS}	B4	V _{BUS}
A5	CC		
A6	D _p		
A7	D _n		
A9	V _{BUS}	B9	V _{BUS}
A12	GND	B12	GND

NO	DESCRIPTION	QTY	MATERIAL	PLATING & COLOR
A	HOUSING	1	LCP E130i+30%G/F UL94V-0	BLACK
B	SPACER	1	LCP E130i+30%G/F UL94V-0	BLACK
C	SHELL	1	SUS304 3/4H, T=0.17mm	50u MIN. NICKEL
D	TEMINALR	7	V _{BUS} /GND PIN: C7035-TM04 OTHER PIN: C5210-SH	GOLD FLASH
E	LATCH	1	SUS304-1/2H, T=0.25mm	N/A

一般公差 TOLERANCES X. ±0.5 XX ±0.15 X ±0.25 XXX ±0.1 ANGLES ±2°		宏致電子股份有限公司 Aces Electronics Co.,Ltd.	
檢驗尺寸標示 SYMBOLS INDICATE CLASSIFICATION DIMENSION	品名 (TITLE) USB2.0 TYPE C PLUG RIVETING TYPE	製圖 (DR) 17/07/26 BRUCE	審核 (CHKD) MARK-C
MARK IS CRITICAL DIM. MARK IS MAJOR DIM.	圖號 (DWG NO.) 55911-011XX-XXX	核准 (APPD) JACK	
表面處理 (FINISH)	比例 (SCALE) 4:1	單位 (UNITS) mm	張數 (SHEET) 1 OF 2
			尺寸 (SIZE) A4
			版次 (REV) B

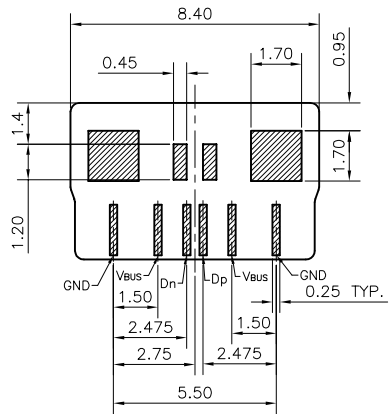

TOP VIEW

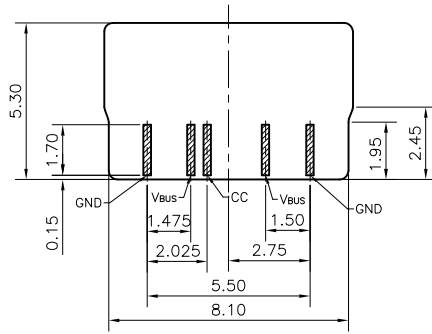

BOTTOM VIEW

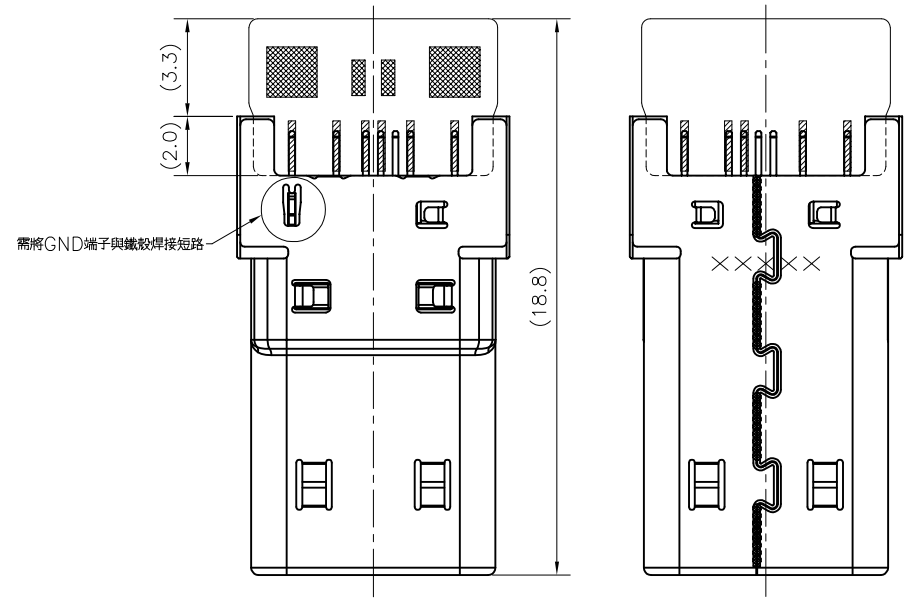

PADDLE CARD ASSEMBLY DIMENSIONS (REF.)

RECOMMENDED PADDLE CARD DIMENSIONS (REF.)
 GENERAL TOLERANCE ± 0.05
 (USED FOR 3A MAX. CURRENT)

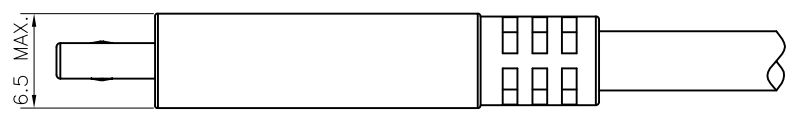
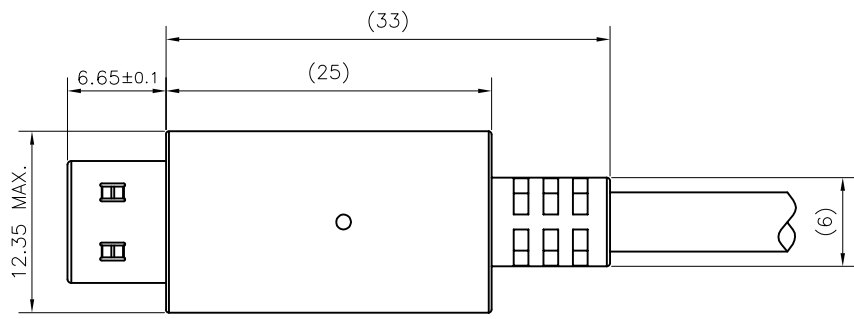

USB TYPE C OVERMOLDING CABLE DIMENSION DRAWING(REF.)

一般公差 TOLERANCES X ± 0.5 XX ± 0.15 X ± 0.25 .XXX ± 0.1 ANGLES $\pm 2^\circ$		宏致電子股份有限公司 Aces Electronics Co.,Ltd.	
檢驗尺寸標示 SYMBOLS $\text{\textcircled{C}}$ $\text{\textcircled{D}}$ INDICATE CLASSIFICATION DIMENSION $\text{\textcircled{C}}$ MARK IS CRITICAL DIM. $\text{\textcircled{D}}$ MARK IS MAJOR DIM.		品名 (TITLE) USB2.0 TYPE C PLUG RIVETING TYPE 圖號 (DWG No.) 55911-011XX-XXX	製圖 (DR) 17/07/26 BRUCE 審核 (CHKD) MARK-C 核准 (APPD) JACK-K
表面處理 (FINISH)	比例 (SCALE) 4:1	單位 (UNITS) mm	張數 (SHEET) 2 OF 2 圖號 (DWG No.) $\text{\textcircled{C}}$ $\text{\textcircled{D}}$
			尺寸 (SIZE) A4 頁數 (REV) B